

MACHINED TYPE NEEDLE ROLLER BEARINGS

With Inner Ring

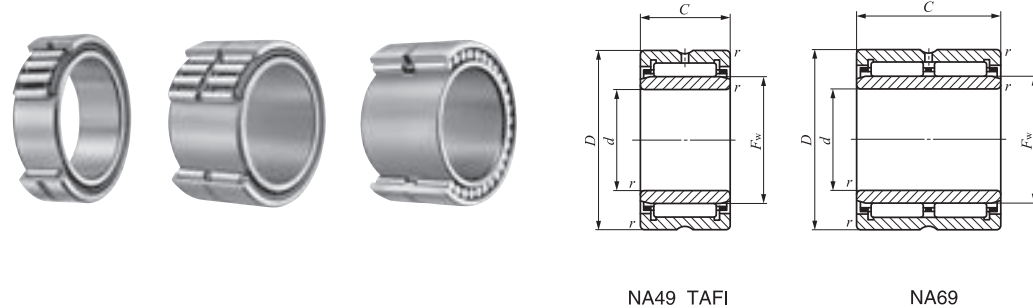

NA49 TAFI

NA69

Shaft dia. 50 – 70mm

Shaft dia. mm	Identification number						Mass (Ref.)	
	NA 49	NA 69	NA 48	TAFI	TRI	GTRI	g	d
50	—	—	—	TAFI 506825	—	—	270	50
	—	—	—	TAFI 506835	—	—	365	50
	NA 4910	—	—	—	—	—	295	50
	—	NA 6910	—	—	—	—	530	50
	—	—	—	—	TRI 507745	—	755	50
	—	—	—	—	—	GTRI 507745	825	50
55	—	—	—	TAFI 557225	—	—	275	55
	—	—	—	TAFI 557235	—	—	380	55
	NA 4911	—	—	—	—	—	410	55
	—	NA 6911	—	—	—	—	730	55
	—	—	—	—	TRI 558138	—	650	55
	—	—	—	—	—	GTRI 558138	710	55
60	—	—	—	TAFI 608225	—	—	395	60
	—	—	—	TAFI 608235	—	—	560	60
	NA 4912	—	—	—	—	—	440	60
	—	NA 6912	—	—	—	—	785	60
	—	—	—	—	TRI 608945	—	960	60
	—	—	—	—	—	GTRI 608945	1 050	60
65	NA 4913	—	—	—	—	—	470	65
	—	—	—	TAFI 659035	—	—	710	65
	—	NA 6913	—	—	—	—	840	65
70	—	—	—	TAFI 709525	—	—	540	70
	—	—	—	TAFI 709535	—	—	755	70
	NA 4914	—	—	—	—	—	765	70
	—	—	—	—	—	—	765	70
	—	NA 6914	—	—	—	—	1 400	70

Notes⁽¹⁾ Minimum allowable value of chamfer dimension *r*
⁽²⁾ Allowable axial shift amount of inner ring to outer ring
⁽³⁾ Allowable rotational speed applies to oil lubrication. For grease lubrication, a maximum of 60% of this value is allowable.
 Remarks1. The outer ring has an oil groove and an oil hole.
 2. No grease is prepacked. Perform proper lubrication.

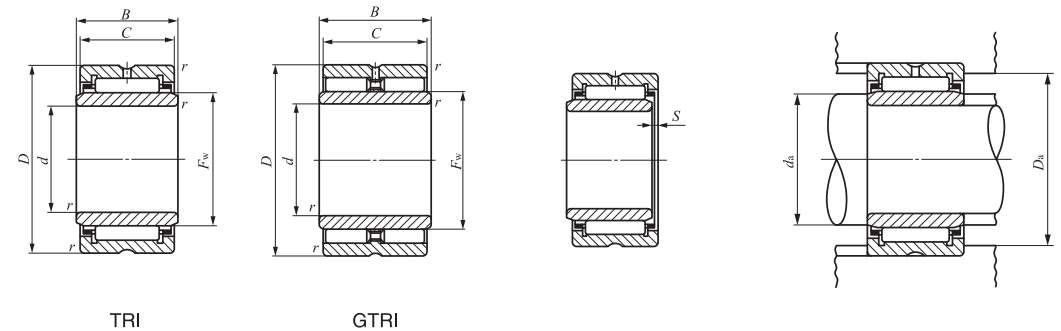

TRI

GTRI

Boundary dimensions mm						Standard mounting dimensions mm			Basic dynamic load rating	Basic static load rating	Allowable rotational speed ⁽³⁾	Assembled inner ring
D	C	B	⁽¹⁾ <i>r_{s min}</i>	<i>F_w</i>	⁽²⁾ <i>S</i>	Min.	<i>d_a</i> Max.	<i>D_a</i> Max.	<i>C</i> N	<i>C₀</i> N	min ⁻¹	
68	25	—	0.3	55	0.5	52	54	66	45 400	94 000	7 500	LRT 505525
68	35	—	0.3	55	1	52	54	66	61 200	138 000	7 500	LRT 505535
72	22	—	0.6	58	0.5	54	57	68	46 200	82 100	7 000	LRT 505822
72	40	—	0.6	58	0.3	54	57	68	79 200	164 000	7 000	LRT 505840
77	45	45.5	1	58	2	55	57	72	104 000	191 000	7 000	LRT 505845
77	45	45.5	1	58	—	55	57	72	135 000	280 000	2 500	LRTZ 505845
72	25	—	0.3	60	0.5	57	59	70	47 500	103 000	6 500	LRT 556025
72	35	—	0.3	60	1	57	59	70	64 100	151 000	6 500	LRT 556035
80	25	—	1	63	1	60	61	75	57 600	97 200	6 500	LRT 556325
80	45	—	1	63	0.5	60	61	75	98 700	194 000	6 500	LRT 556345
81	38	38.5	1	62	1.5	60	60.5	76	92 000	166 000	6 500	LRT 556238
81	38	38.5	1	62	—	60	60.5	76	118 000	241 000	2 500	LRTZ 556238
82	25	—	0.6	68	0.3	64	66	78	54 800	117 000	6 000	LRT 606825
82	35	—	0.6	68	1	64	66	78	72 000	166 000	6 000	LRT 606835
85	25	—	1	68	1	65	66	80	60 200	105 000	6 000	LRT 606825-1
85	45	—	1	68	0.5	65	66	80	103 000	211 000	6 000	LRT 606845
89	45	45.5	1	70	2	65	68	84	114 000	228 000	5 500	LRT 607045
89	45	45.5	1	70	—	65	68	84	147 000	336 000	2 000	LRTZ 607045
90	25	—	1	72	1	70	70.5	85	62 700	113 000	5 500	LRT 657225
90	35	—	1	73	1	70	71	85	80 400	181 000	5 500	LRT 657335
90	45	—	1	72	0.5	70	70.5	85	108 000	227 000	5 500	LRT 657245
95	25	—	1	80	0.3	75	78	90	59 400	137 000	5 000	LRT 708025
95	35	—	1	80	1	75	78	90	78 100	195 000	5 000	LRT 708035
100	30	—	1	80	1.5	75	78	95	83 200	158 000	5 000	LRT 708030
100	54	—	1	80	1	75	78	95	134 000	311 000	5 000	LRT 708054

D

NA
TAFI
TRI
BRI